

# JENBO

JNB-35B-W JNB-35B-B

## HID Track Lamp Fixture

### LAMP WATTAGE

(1) HID35/PAR20 (1) HID35/PAR30L  
(1) HID35/PAR30L (1) HID70/PAR36

### DESCRIPTION

High Intensity Discharge (HID) gimbal and lamp holder. Utilizes electronic metal halide ballast designed for use with higher CRI Index MasterColor (or equivalent) PAR metal halide light sources.

### FEATURES

- Electronic ballast
- Deep drawn steel socket cup housing for high strength and rigidity
- Heat resistant Teflon coated wire lead
- High-strength stainless steel electrical contacts
- One or two circuit track capable

### HOUSING, SOCKET CUP

.025 Deep drawn steel construction with softened edges. "L" gimbal allows socket to be adjusted into any position for optimal lighting performance and fixture appearance.

### BALLAST

Integral high power factor electronic solid state Type-1 ballast housed in .030 finished steel enclosure. Ballast provides automatic termination upon end of lamp life. i.e. "End of Life" protection.

Power Factor: >95%  
Sound Rating: A  
Frequency: 170 Hz (square wave)  
Min. Starting Temp.: 5F (-15°C)  
Total Harmonic Distortion: <10%  
Ballast Life Expectancy: 56,000 hours (at 75C)  
Input Power: 35W  
Input Watts: 44  
Operating Amps: .37

### SOCKET

4KV 660VA/600V Porcelain jacketed aluminum screw thread medium-base socket.

### WIRING

Teflon coated wire lead connects socket and housing to electrical contact head. Teflon coating is durable and resists heat degradation from lamp and housing radiation.

### CONTACT HEAD ASSEMBLY

Three .030 stainless steel contacts mounted in high heat rated plastic housing.

### ONE/TWO CIRCUIT CONVERSION

Positive contact (opposite neutral and ground contacts) is preset to "down" position at factory, but may be raised to the higher position to install onto the second circuit of Jenbo Lighting JB-2300 series two-circuit track.

### FINISHES

White or Black heat rated baked enamel paint. Custom painting or anodizing for special applications is also available. Custom finishes will require lead times that vary depending on vendor schedules. Please consult

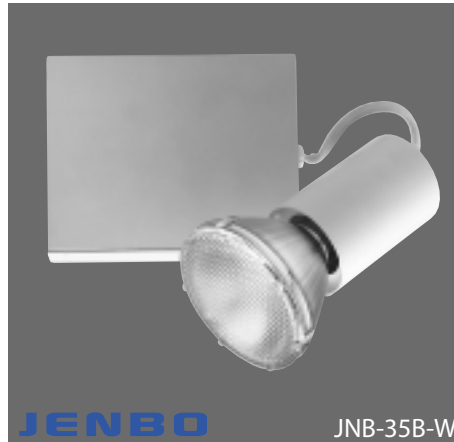

### PRODUCT MATRIX

JNB-35B-W	W HID35/PAR20 HID Lamp Holder
JNB-35B-B	B HID35/PAR36L HID Lamp Holder

### DIMENSIONS

#### JNB - 35B - W

A: Diameter	2-1/2"	(64 mm)
B: Length	4"	(102 mm)
C: Max Extension	7-3/8"	(187 mm)

#### JNB - 35B - B

A: Diameter	3-3/4"	(95 mm)
B: Length	4-5/8"	(117 mm)
C: Max Extension	8-3/8"	(21 cm)

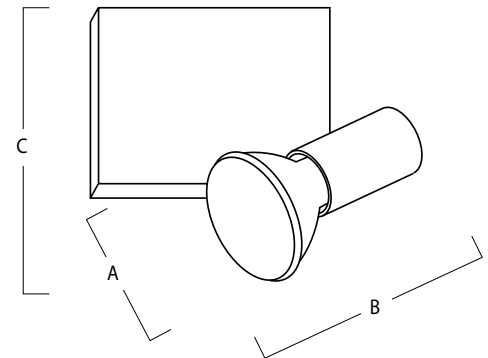

factory for quotation, and provide either a Dunn Edwards number or color chip for exact matching.

### UL LISTED

UL Listed as track lighting fitting

### ACCESSORIES

Custom Finishes .....Consult Factory